

LINETRAXX® CTAC series

Measuring current transformers





Product description

The highly sensitive CTAC series measuring current transformers in combination with RCM or RCMS series residual current monitors and evaluators convert AC currents into an evaluable measurement signal.

They are also suitable for use in insulation fault location systems for IT systems (EDS). The current transformers measure the locating current generated by a PGH locating current injector or an ISOMETER® iso685. In combination with EDS series insulation fault locators, the locating current is converted into an evaluable measurement signal.

The connection to the respective devices is made via a two-wire cable.

Wiring diagram

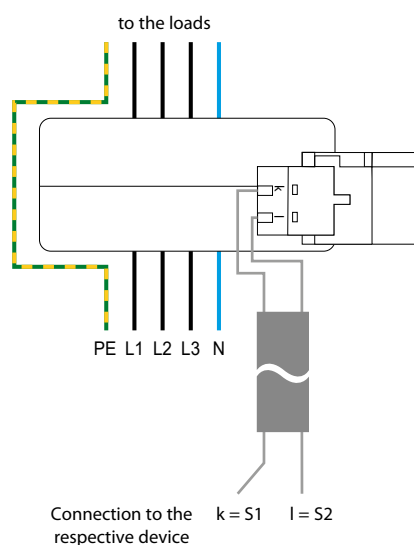

Measuring current transformers CTAC...

Connection to the respective residual current monitoring system RCMS, residual current monitors RCM or to insulation fault location systems EDS.

Measuring current transformers CTAC.../01

Connection to the respective insulation fault locator EDS441.

Device features

Measuring current transformers CTAC...

- For RCMS residual current monitoring systems
- For RCM420 residual current monitors
- For EDS440 insulation fault locators in AC and DC systems

Measuring current transformers CTAC.../01

- For EDS441 insulation fault locators

Approvals and certifications



Ordering information

Mounting	Inside diameter	Type	Art. No. ²⁾
Mounting brackets, DIN rail	20 mm	CTAC20	B98110005
		CTAC20/01 ¹⁾	B98110006
	35 mm	CTAC35	B98110007
		CTAC35/01 ¹⁾	B98110008
Mounting brackets	120 mm	CTAC120	B98110019
	210 mm	CTAC210	B98110020

¹⁾ For EDS441 and EDS461/491 insulation fault locators

²⁾ B781100xxMIL variants available on request

Selection list

Type	RCM420	RCMS460 RCMS490	RCMS410 RCMS425	EDS440	EDS441
CTAC20	✓	✓	✓	✓	–
CTAC35	✓	✓	✓	✓	–
CTAC60	✓	✓	✓	✓	–
CTAC120	✓	✓	✓	✓	–
CTAC210	✓	✓	✓	✓	–
CTAC20/01	–	–	–	–	✓
CTAC35/01	–	–	–	–	✓

Accessories

Description	Art. No.
Snap-on mounting for CTAC20 and CTAC20/01	B91080111
Snap-on mounting for CTAC35 and CTAC35/01	B91080112

Included in scope of delivery



Dimension diagrams

CTAC20(/01)/CTAC35(/01)

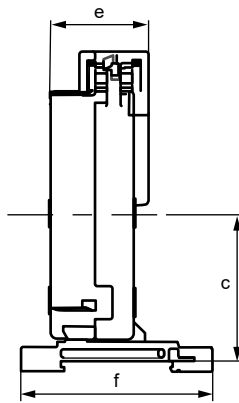
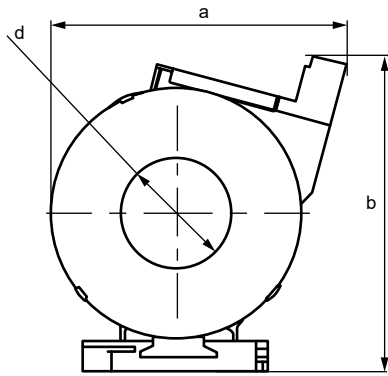

CTAC60

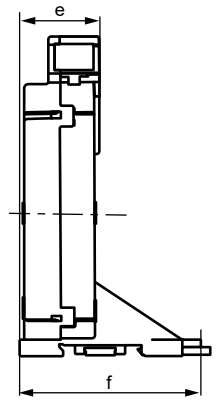
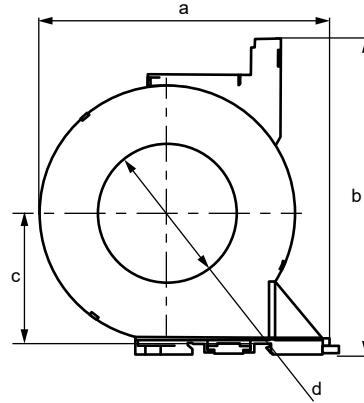

CTAC120/CTAC210

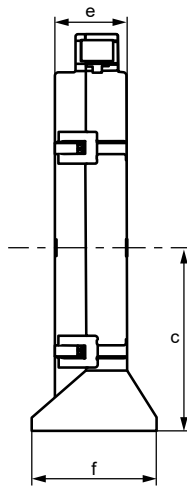
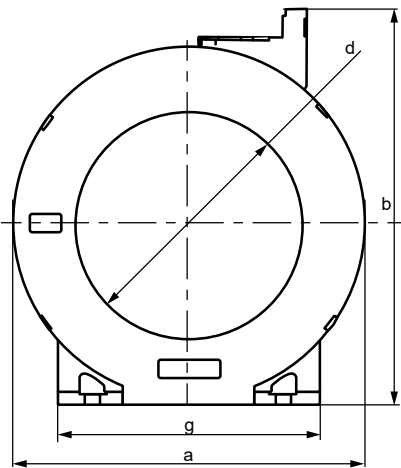

Type	Dimensions (mm)							Weight in g (gross)
	a	b	c	d	e	f	g	
CTAC20(/01)	75	82	37	∅ 20	32	60	–	160
CTAC35(/01)	94	100	47	∅ 35	30	61	–	220
CTAC60	126	137	57	∅ 60	33	78	–	460
CTAC120	188	211	96	∅ 120	38	66	139	1140
CTAC210	302	324	153	∅ 210	40	74	277	2340

Tolerance: ±0.5 mm

Mountings

CTAC20(/01)/CTAC35(/01)

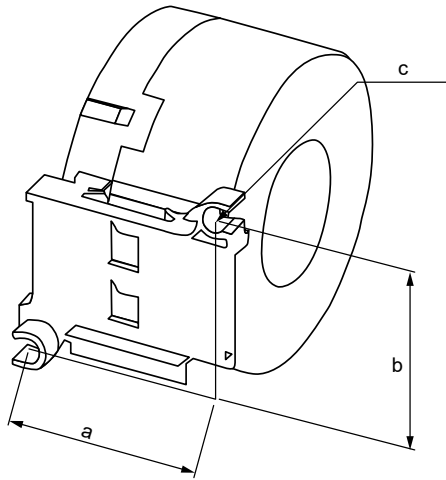

CTAC60(/01)

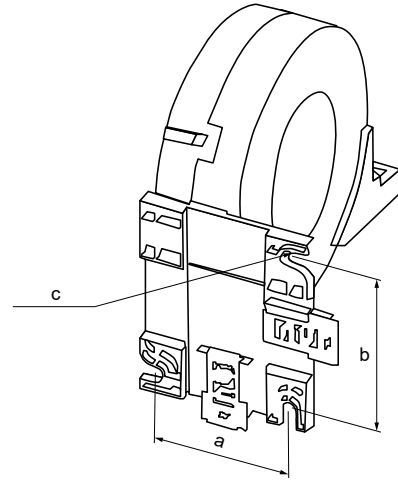

CTAC120/CTAC210

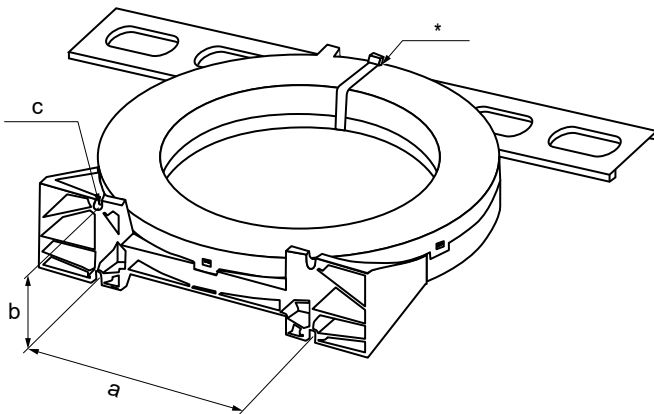

Dimensions (mm) (mm)			
Type	a	b	c
CTAC20(/01)	31.4	49	2 x ø 5.5
CTAC35(/01)	49.8	49	2 x ø 5.5
CTAC60	56	66	3 x ø 6.5
CTAC120	103	51	4 x ø 6.5
CTAC210	180	59	4 x ø 6.5

* Mounting for CTAC120/210MIL variants

Installation instructions

- Do not route any shielded cables through the measuring current transformer.
- If the installation instructions are not followed, the tolerances and normative requirements of the connected monitoring devices may not be fulfilled.

<p>All current-carrying cables must be routed together through the measuring current transformer.</p>		<p>The primary conductors may only be bent from the specified minimum distance. The minimum bending radius specified by the manufacturers must be observed. * Distance to 90° angle: 2x external diameter of the current transformer</p>	
<p>Never route an existing protective conductor through the measuring current transformer.</p>		<p>The cables must be centred in the measuring current transformer.</p>	
		<p>Internal diameter of the measuring current transformer $d2 \geq 2 \times d1$ (cable diameter)</p>	

Technical data
Insulation coordination acc. to IEC 60664-1

Rated insulation voltage	800 V
Overvoltage category	III
Rated impulse voltage/pollution degree	8 kV / 3

Measuring current transformer circuit
CTAC...

Rated transformation ratio K_r	600 / 1
Rated continuous thermal current ¹⁾ I_{cth}	125 A
Frequency range	15 Hz...100 kHz
Rated short-time thermal current ¹⁾ I_{th}	2.4 kA / 1 s
Rated dynamic current ¹⁾ I_{dyn}	50 kA / 50 ms

 Rated current I

CTAC20 at $I_{\Delta n} \geq 30$ mA	63 A
CTAC20 at $I_{\Delta n} \geq 300$ mA	80 A
CTAC35 at $I_{\Delta n} \geq 30$ mA	125 A
CTAC35 at $I_{\Delta n} \geq 300$ mA	160 A
CTAC60 at $I_{\Delta n} \geq 30$ mA	200 A
CTAC60 at $I_{\Delta n} \geq 300$ mA	400 A
CTAC120 at $I_{\Delta n} \geq 100$ mA	400 A
CTAC210 at $I_{\Delta n} \geq 300$ mA	630 A

CTAC.../01

Rated transformation ratio K_r	8000 / 1
Rated continuous thermal current ¹⁾ I_{cth}	6 A
Rated short-time thermal current ¹⁾ I_{th}	0.36 kA / 1 s
Rated dynamic current ¹⁾ I_{dyn}	0.9 kA / 40 ms

 Rated current I

CTAC20/01 at $I_{\Delta n} \geq 30$ mA	63 A
CTAC20/01 at $I_{\Delta n} \geq 300$ mA	80 A
CTAC35/01 at $I_{\Delta n} \geq 30$ mA	125 A
CTAC35/01 at $I_{\Delta n} \geq 300$ mA	160 A

¹⁾ refers to the residual current

Environment

Operating temperature	-25...+70 °C
B781100xxMIL (for applications with EDS)	-40...+70 °C

Climatic class acc. to IEC 60721 (except condensation and formation of ice)

Stationary use (IEC 60721-3-3)	3K23
Transport (IEC 60721-3-2)	2K11
Long-time storage (IEC 60721-3-1)	1K22

Classification of mechanical conditions IEC 60721

Stationary use (IEC 60721-3-3)	3M11
B781100xxMIL devices ¹⁾	3M12
Transport (IEC 60721-3-2)	2M4
Long-time storage (IEC 60721-3-1)	1M12

¹⁾ CTAC120 and CTAC210 must be additionally mounted for the 3M12.
(see Mountings)

Connection

Terminal type	MSTB 2.5/2-ST-5.08
for B781100xxMIL devices	FKC 2.5/2-ST-5.08
Manufacturer	Phoenix Contact
Connection type	screw type terminal
for B781100xxMIL devices	push-wire terminal

The connection conditions of the manufacturer apply.

Corresponding PCB connectors are included in the scope of delivery

Connection properties

rigid	0.2...2.5 mm ² (AWG24...12)
flexible	0.2...2.5 mm ² (AWG 24...12)
Stripping length	7 mm

Connection EDS, RCM(S) measuring current transformers

Single wire ≥ 0.75 mm ²	0...1 m
Single wire, twisted ≥ 0.75 mm ²	0...10 m
Shielded cable ≥ 0.5 mm ²	0...40 m
Shielded cable	recommended: J-Y(St)Y min. 2x0.8
RCM: shield on one side connected to L-conductor, not connected to earth	
EDS: shield on one side connected to PE	

Mounting
Screw Type

CTAC20(/01), CTAC35(/01), CTAC60	DIN EN ISO 7045 - M5x
CTAC120, CTAC210	DIN EN ISO 7045 - M6

Washer type

CTAC20(/01), CTAC35(/01), CTAC60	DIN EN ISO 7089/7090 - 5
CTAC120, CTAC210	DIN EN ISO 7089/7090 - 6

Tightening torque

CTAC20(/01), CTAC35(/01)	0.6 Nm
CTAC60, CTAC120, CTAC210	1 Nm

Other

Degree of protection, internal components (DIN EN 60529)	IP40
Degree of protection, terminals (IEC 60529)	IP20
Flammability class	UL94 V-0
Documentation number	D00386



Bender GmbH & Co. KG

Londorfer Straße 65
35305 Grünberg
Germany

Tel.: +49 6401 807-0
info@bender.de
www.bender.de



© Bender GmbH & Co. KG, Germany
Subject to change!
The specified standards take into account the
edition valid until 12.2025 unless otherwise
indicated.